

Introduction to UML

CSCE A222

What is UML?

- Unified Modeling Language
 - OMG Standard, Object Management Group
 - Based on work from Booch, Rumbaugh, Jacobson
- UML is a modeling language to express and design documents, software
 - Particularly useful for OO design
 - Not a process, but some have been proposed using UML
 - Independent of implementation language

Why use UML

- Open Standard, Graphical notation for
 - Specifying, visualizing, constructing, and documenting software systems
- Language can be used from general initial design to very specific detailed design across the entire software development lifecycle
- Increase understanding/communication of product to customers and developers
- Support for diverse application areas
- Support for UML in many software packages today (e.g. Visual Studio, plugins for popular IDE's like NetBeans, Eclipse)
- Based upon experience and needs of the user community

Brief History

- Inundated with methodologies in early 90's
 - Booch, Jacobson, Yourden, Rumbaugh
- Booch, Jacobson merged methods 1994
- Rumbaugh joined 1995
- 1997 UML 1.1 from OMG includes input from others, e.g. Yourden
- UML v2.5 current version

History of UML

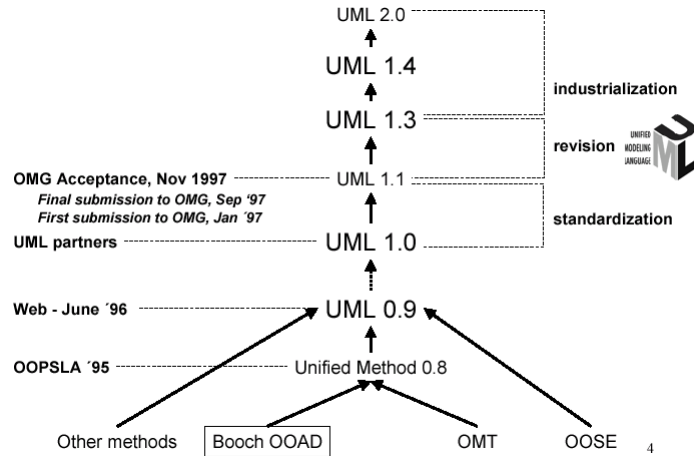

Contributions to UML

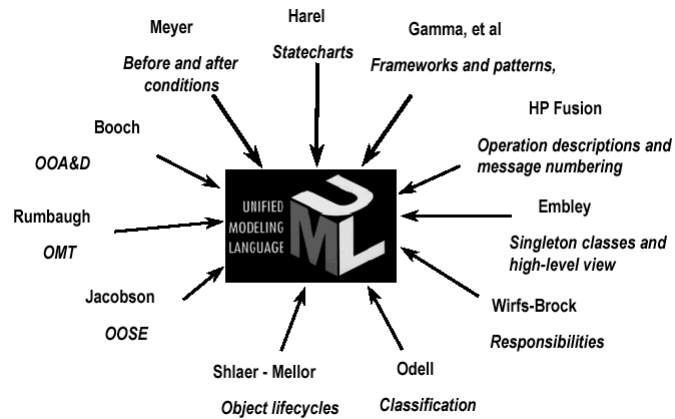

UML Models, Views, Diagrams

- UML is a multi-diagrammatic language
 - Each diagram is a view into a model
 - Diagram presented from the aspect of a particular stakeholder
 - Provides a partial representation of the system
 - Is semantically consistent with other views
 - Example views

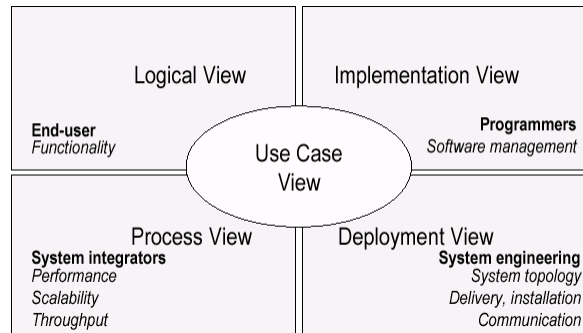

Models, Views, Diagrams

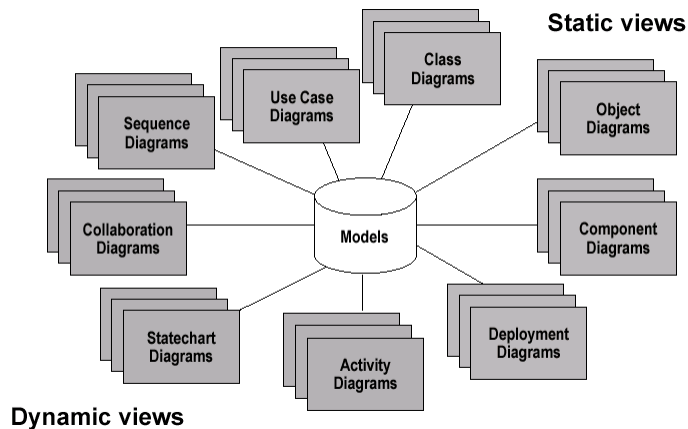

UML: First Pass

- You can model 80% of most problems by using about 20 % UML
- We only cover the 20% here

UML Baseline

- Use Case Diagrams
- Class Diagrams
- Package Diagrams
- Interaction Diagrams
 - Sequence
 - Collaboration
- Activity Diagrams
- State Transition Diagrams
- Deployment Diagrams

Use Case Diagrams

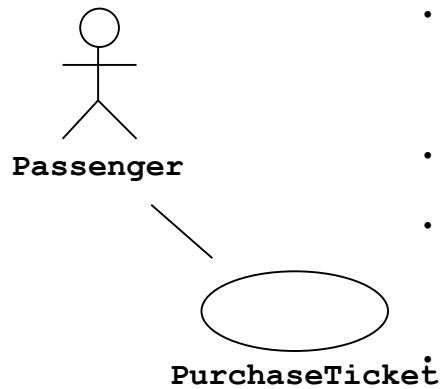

- Used during requirements elicitation to represent external behavior
 - **Actors** represent roles, that is, a type of user of the system
 - **Use cases** represent a sequence of interaction for a type of functionality; summary of scenarios
- The use case model is the set of all use cases. It is a complete description of the functionality of the system and its environment

Actors

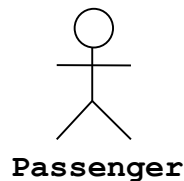

- An actor models an external entity which communicates with the system:
 - User
 - External system
 - Physical environment
- An actor has a unique name and an optional description.
- Examples:
 - Passenger: A person in the train
 - GPS satellite: Provides the system with GPS coordinates

Use Case

A use case represents a class of functionality provided by the system as an event flow.

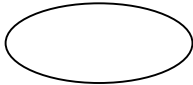

PurchaseTicket

A use case consists of:

- Unique name
- Participating actors
- Entry conditions
- Flow of events
- Exit conditions
- Special requirements

Use Case Diagram: Example

Name: Purchase ticket

Participating actor: Passenger

Entry condition:

- Passenger standing in front of ticket distributor.
- Passenger has sufficient money to purchase ticket.

Exit condition:

- Passenger has ticket.

Event flow:

1. Passenger selects the number of zones to be traveled.
2. Distributor displays the amount due.
3. Passenger inserts money, of at least the amount due.
4. Distributor returns change.
5. Distributor issues ticket.

Anything missing?

Exceptional cases!

The <<extends>> Relationship

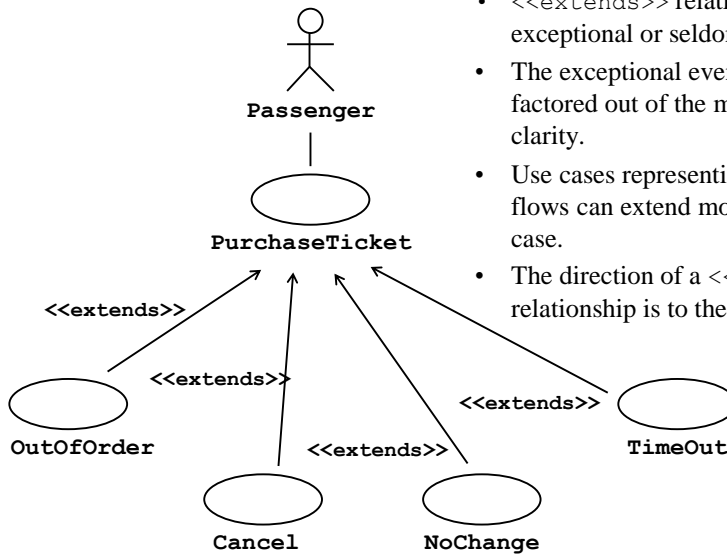

- <<extends>> relationships represent exceptional or seldom invoked cases.
- The exceptional event flows are factored out of the main event flow for clarity.
- Use cases representing exceptional flows can extend more than one use case.
- The direction of a <<extends>> relationship is to the extended use case

The <<includes>> Relationship

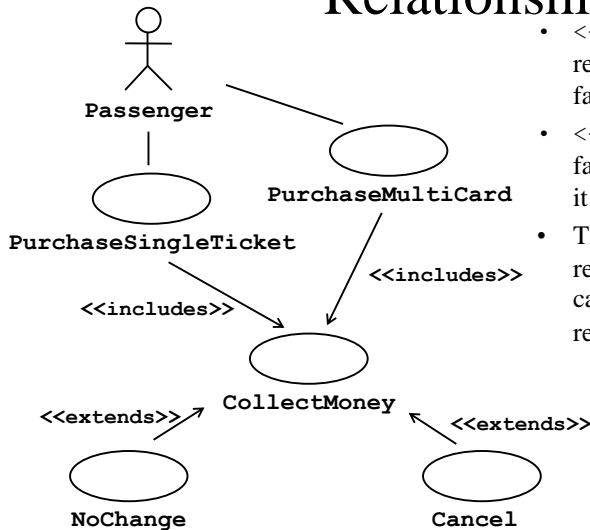

- <<includes>> relationship represents behavior that is factored out of the use case.
- <<includes>> behavior is factored out for reuse, not because it is an exception.
- The direction of a <<includes>> relationship is to the using use case (unlike <<extends>> relationships).

Use Cases are useful for...

- Determining requirements
 - New use cases often generate new requirements as the system is analyzed and the design takes shape.
- Communicating with clients
 - Their notational simplicity makes use case diagrams a good way for developers to communicate with clients.
 - May require some explanation.
- Generating test cases
 - The collection of scenarios for a use case may suggest a suite of test cases for those scenarios.

Use Case Diagrams: Summary

- Use case diagrams represent external behavior
- Use case diagrams are useful as an index into the use cases
- Use case descriptions provide meat of model, not the use case diagrams.
- All use cases need to be described for the model to be useful.

Use Case Exercise

- Create use cases for buying a beverage from the eXpress coffee shop in EIB.

Class Diagrams

- Gives an overview of a system by showing its classes and the relationships among them.
 - Class diagrams are static
 - they display what interacts but not what happens when they do interact
- Also shows attributes and operations of each class
- Good way to describe the overall architecture of system components

Class Diagram Perspectives

- We draw Class Diagrams under three perspectives
 - Conceptual
 - Software independent
 - Language independent
 - Specification
 - Focus on the interfaces of the software
 - Implementation
 - Focus on the implementation of the software

Classes – Not Just for Code

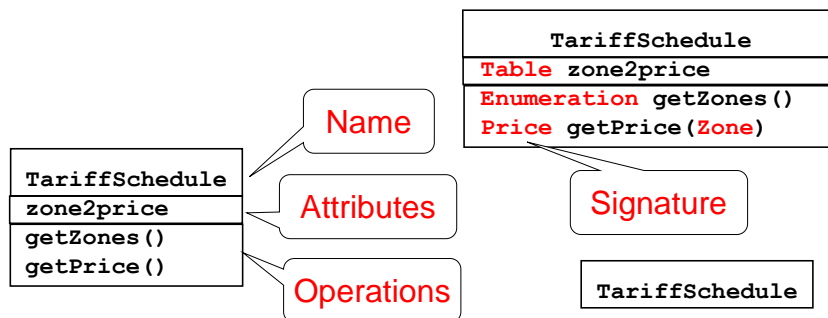

- A *class* represent a concept
- A class encapsulates state (*attributes*) and behavior (*operations*).
- Each attribute has a *type*.
- Each operation has a *signature*.
- The class name is the only mandatory information.

Instances

<code>tarif 1974:TariffSchedule</code>
<code>zone2price = { {'1', .20}, {'2', .40}, {'3', .60}}</code>

- An *instance* represents a phenomenon.
- The name of an instance is underlined and can contain the class of the instance.
- The attributes are represented with their *values*.

UML Class Notation

- A class is a rectangle divided into three parts
 - Class name
 - Class attributes (i.e. data members, variables)
 - Class operations (i.e. methods)
- Modifiers
 - Private: -
 - Public: +
 - Protected: #
 - Static: Underlined (i.e. shared among all members of the class)
- Abstract class: Name in italics

Employee
-Name : string +ID : long #Salary : double
+getName() : string +setName() -calcInternalStuff(in x : byte, in y : decimal)

UML Class Notation

- Lines or arrows between classes indicate relationships
 - Association
 - A relationship between instances of two classes, where one class must know about the other to do its work, e.g. client communicates to server
 - indicated by a straight line or arrow
 - Aggregation
 - An association where one class belongs to a collection, e.g. instructor part of Faculty
 - Indicated by an empty diamond on the side of the collection
 - Composition
 - Strong form of Aggregation
 - Lifetime control; components cannot exist without the aggregate
 - Indicated by a solid diamond on the side of the collection
 - Inheritance
 - An inheritance link indicating one class a superclass relationship, e.g. bird is part of mammal
 - Indicated by triangle pointing to superclass

Binary Association

Binary Association: Both entities “Know About” each other

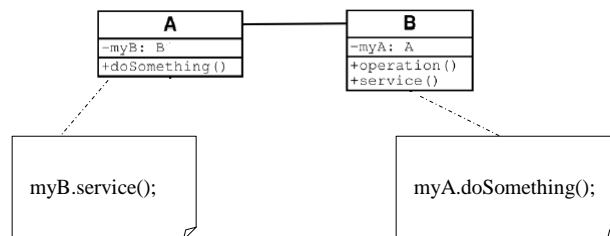

Unary Association

A knows about B, but B knows nothing about A

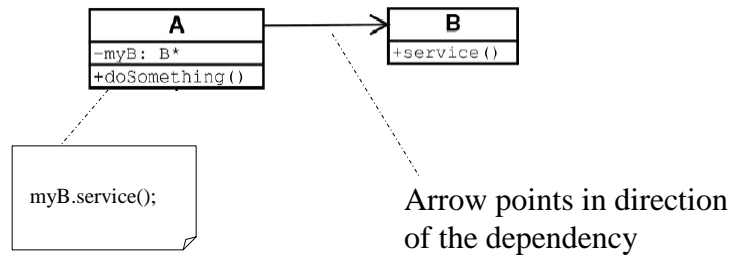

Aggregation

Aggregation is an association with a “collection-member” relationship

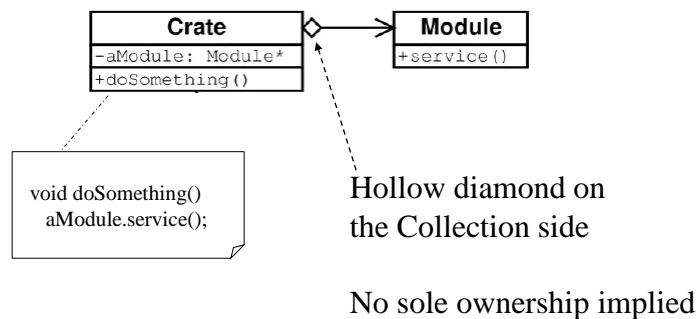

Composition

Composition is Aggregation with:

Lifetime Control (owner controls construction, destruction)

Part object may belong to only one whole object

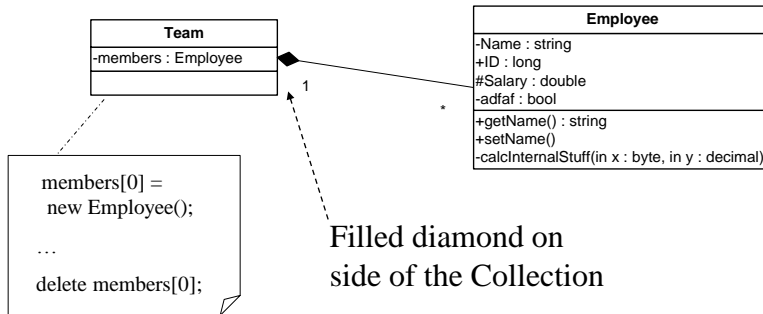

Inheritance

Standard concept of inheritance

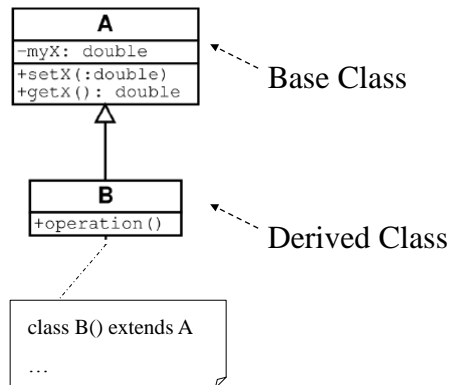

UML Multiplicities

Links on associations to specify more details about the relationship

Multiplicities	Meaning
0..1	zero or one instance. The notation $n..m$ indicates n to m instances.
0..* or *	no limit on the number of instances (including none).
1	exactly one instance
1..*	at least one instance

UML Class Example

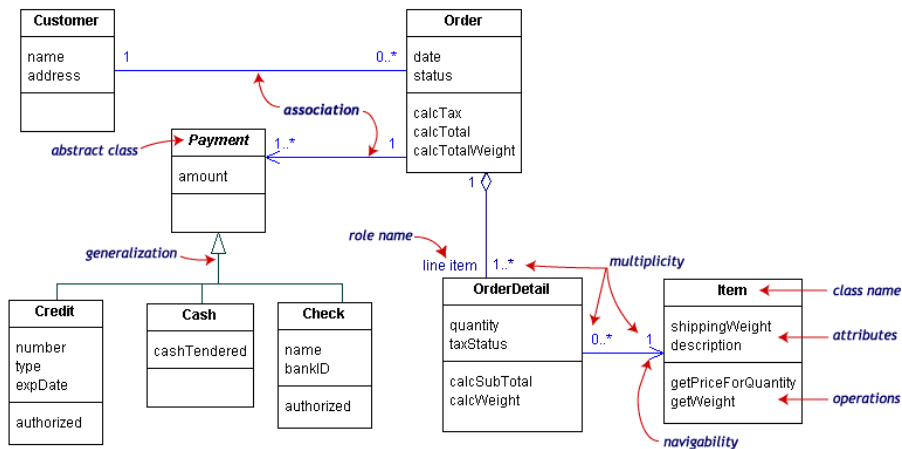

Association Details

- Can assign names to the ends of the association to give further information

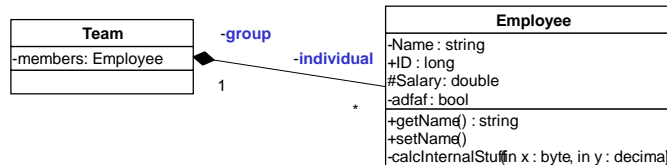

Class Exercise

- Create class diagrams for eXpress scenario.

Class Exercise

- Create class diagrams for the Alien exercise.

Static vs. Dynamic Design

- Static design describes code structure and object relations
 - Class relations
 - Objects at design time
 - Doesn't change
- Dynamic design shows communication between objects
 - Similarity to class relations
 - Can follow sequences of events
 - May change depending upon execution scenario
 - Called Object Diagrams

Object Diagrams

- Shows instances of Class Diagrams and links among them
 - An object diagram is a snapshot of the objects in a system
 - At a point in time
 - With a selected focus
 - Interactions – Sequence diagram
 - Message passing – Collaboration diagram
 - Operation – Deployment diagram

Object Diagrams

- Format is
 - Instance name : Class name
 - Attributes and Values
- Example:

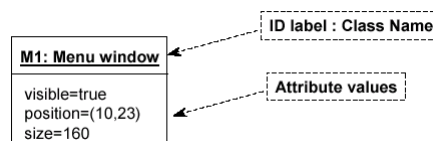

Objects and Links

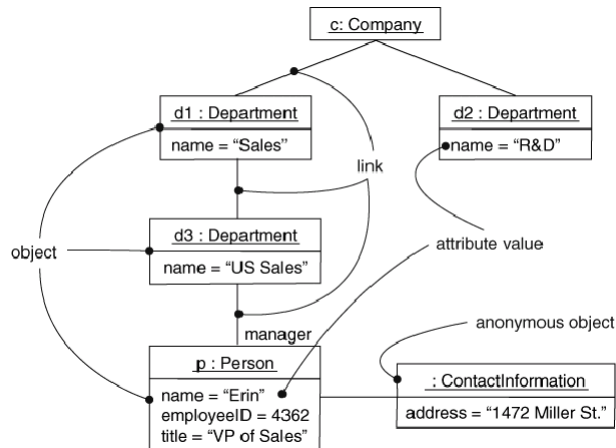

Can add association type and also message type

Package Diagrams

- To organize complex class diagrams, you can group classes into packages. A package is a collection of logically related UML elements
- Notation
 - Packages appear as rectangles with small tabs at the top.
 - The package name is on the tab or inside the rectangle.
 - The dotted arrows are dependencies. One package depends on another if changes in the other could possibly force changes in the first.
 - Packages are the basic grouping construct with which you may organize UML models to increase their readability

Package Example

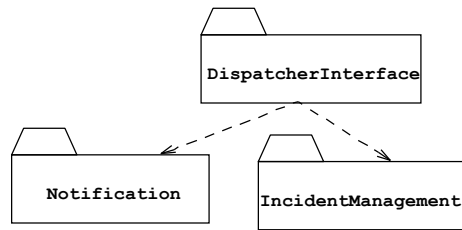

More Package Examples

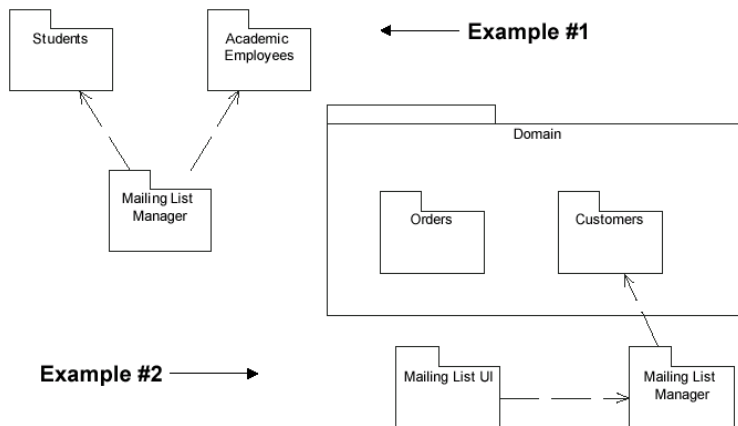

Interaction Diagrams

- Interaction diagrams are dynamic -- they describe how objects collaborate.
- A Sequence Diagram:
 - Indicates what messages are sent and when
 - Time progresses from top to bottom
 - Objects involved are listed left to right
 - Messages are sent left to right between objects in sequence

Sequence Diagram Format

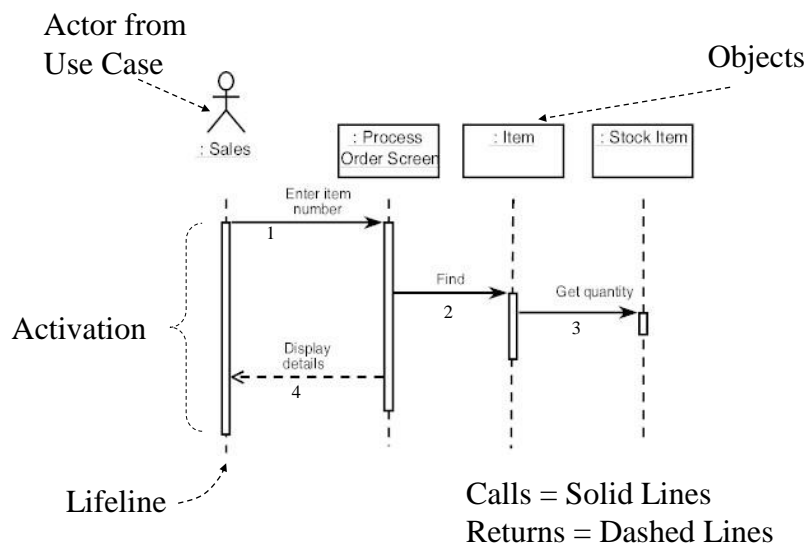

Sequence Diagram : Destruction

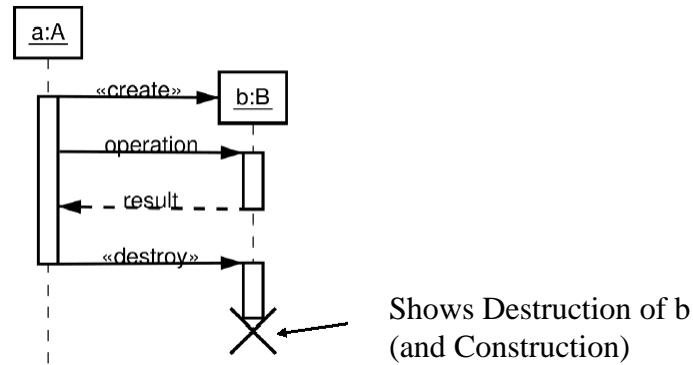

Sequence Diagram : Timing

Slanted Lines show propagation delay of messages
Good for modeling real-time systems

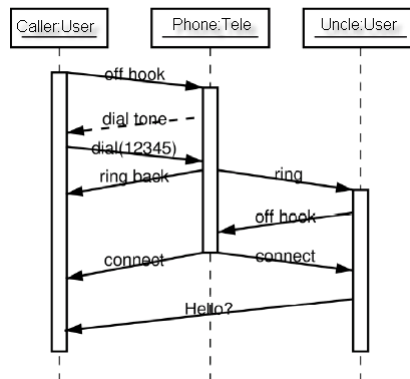

If messages cross this is usually problematic – race conditions

Sequence Example: Alarm System

- When the alarm goes off, it rings the alarm, puts a message on the display, notifies the monitoring service

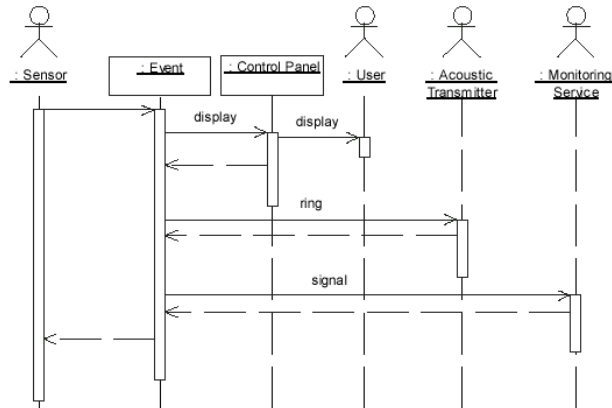

Sequence Diagram Example

Hotel Reservation

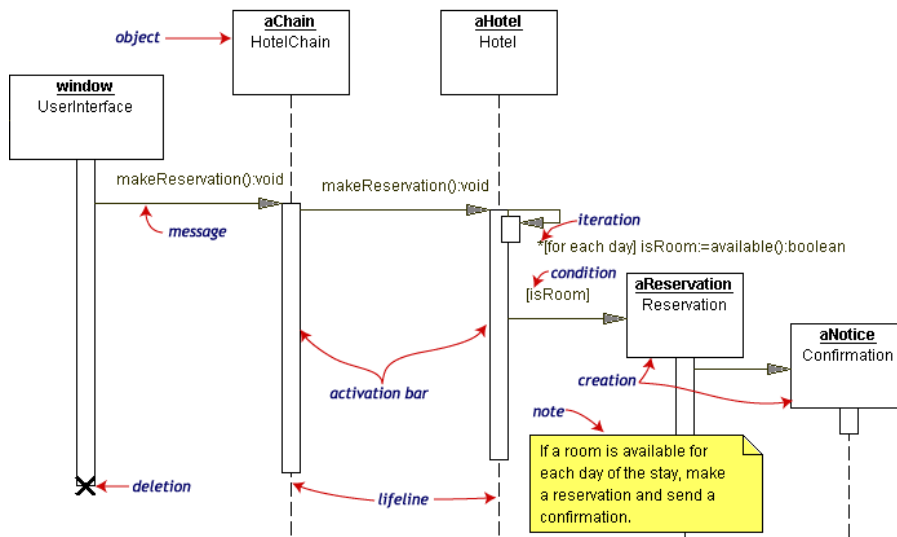

Sequence Exercise

- Create a sequence diagrams for the eXpress example.



Collaboration Diagram

- Collaboration Diagrams show similar information to sequence diagrams, except that the vertical sequence is missing. In its place are:
 - Object Links - solid lines between the objects that interact
 - On the links are Messages - arrows with one or more message name that show the direction and names of the messages sent between objects
- Emphasis on static links as opposed to sequence in the sequence diagram

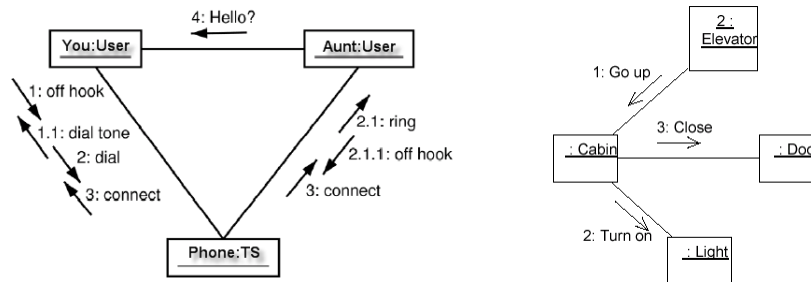
Collaboration Diagram



Activity Diagrams

- Fancy flowchart
 - Displays the flow of activities involved in a single process
 - States
 - Describe what is being processed
 - Indicated by boxes with rounded corners
 - Swim lanes
 - Indicates which object is responsible for what activity
 - Branch
 - Transition that branch
 - Indicated by a diamond
 - Fork
 - Transition forking into parallel activities
 - Indicated by solid bars
 - Start and End
 - 
 - 

Sample Activity Diagram

- Ordering System
- May need multiple diagrams from other points of view

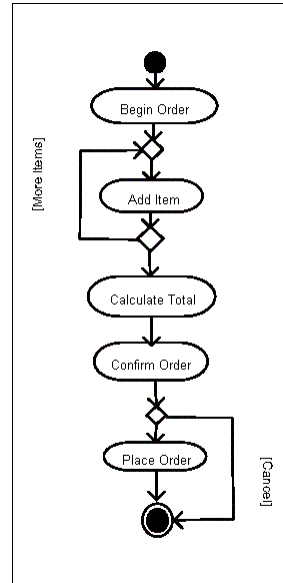

Activity Diagram Example

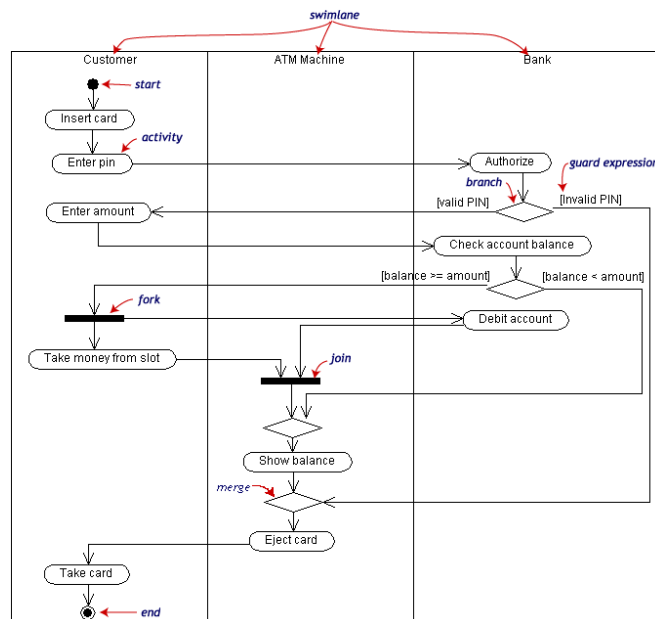

Activity Exercise

- Create activity diagrams for the eXpress example.

State Transition Diagrams

- Fancy version of a DFA
- Shows the possible states of the object and the transitions that cause a change in state
 - i.e. how incoming calls change the state
- Notation
 - States are rounded rectangles
 - Transitions are arrows from one state to another. Events or conditions that trigger transitions are written beside the arrows.
 - Initial and Final States indicated by circles as in the Activity Diagram
 - Final state terminates the action; may have multiple final states

State Representation

- The set of properties and values describing the object in a well defined instant are characterized by
 - Name
 - Activities (executed inside the state)
 - Do/ activity
 - Actions (executed at state entry or exit)
 - Entry/ action
 - Exit/ action
 - Actions executed due to an event
 - Event [Condition] / Action ^Send Event

Notation for States

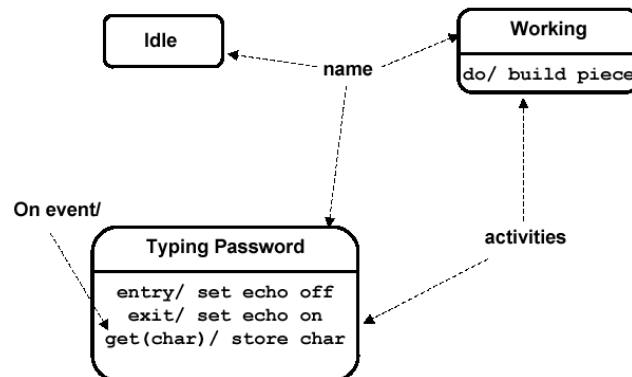

Simple Transition Example

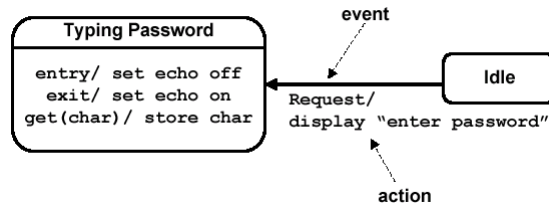

More Simple State Examples

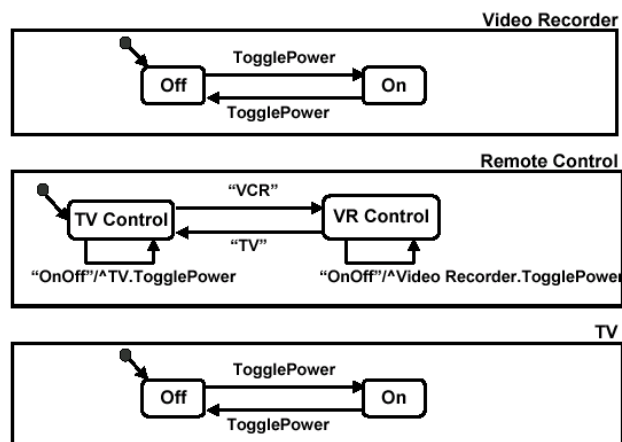

State Transition Example

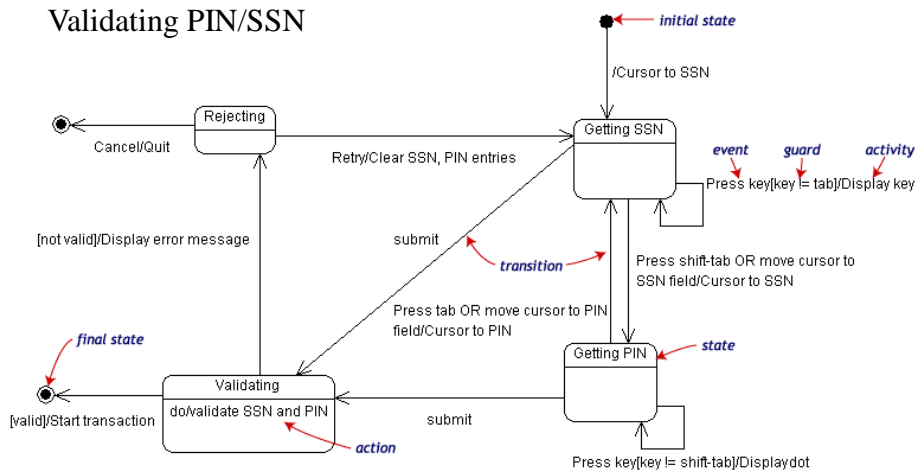

State Charts – Local Variables

- State Diagrams can also store their own local variables, do processing on them
- Library example counting books checked out and returned

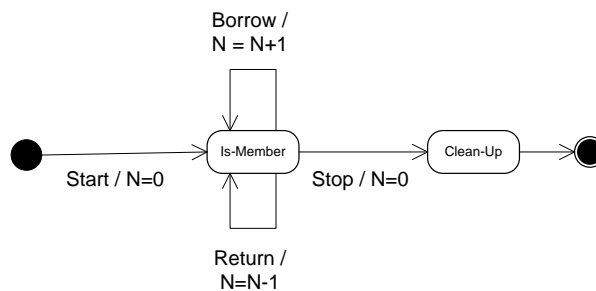

Component Diagrams

- Shows various components in a system and their dependencies, interfaces
- Explains the structure of a system
- Usually a physical collection of classes
 - Similar to a Package Diagram in that both are used to group elements into logical structures
 - With Component Diagrams all of the model elements are private with a public interface whereas Package diagrams only display public items.

Component Diagram Notation

- Components are shown as rectangles with two tabs at the upper left

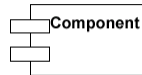

- Dashed arrows indicate dependencies
- Circle and solid line indicates an interface to the component

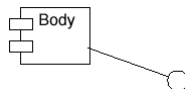

Component Example - Interfaces

- Restaurant ordering system
- Define interfaces first – comes from Class Diagrams

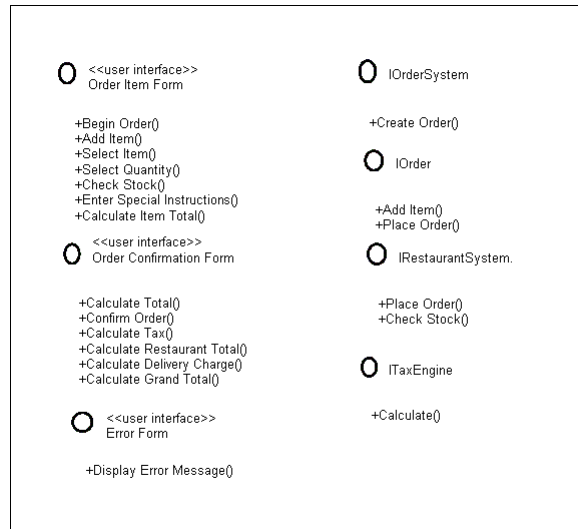

Component Example - Components

- Graphical depiction of components

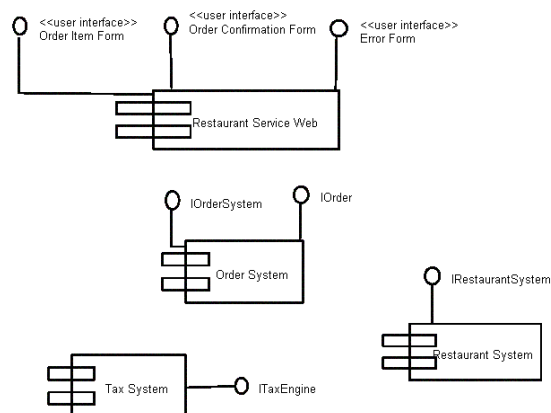

Component Example - Linking

- Linking components with dependencies

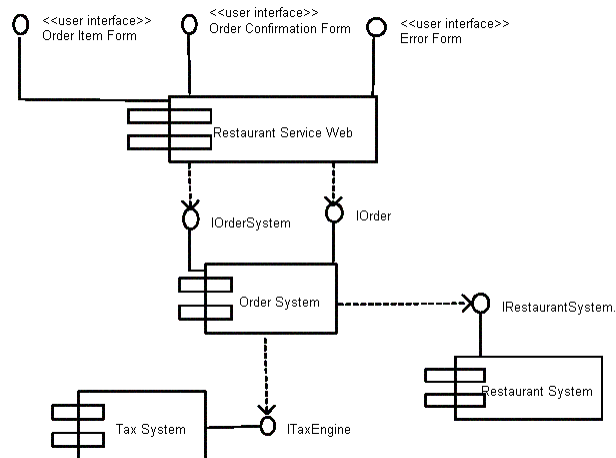

Deployment Diagrams

- Shows the physical architecture of the hardware and software of the deployed system
- Nodes
 - Typically contain components or packages
 - Usually some kind of computational unit; e.g. machine or device (physical or logical)
- Physical relationships among software and hardware in a delivered systems
 - Explains how a system interacts with the external environment

Some Deployment Examples

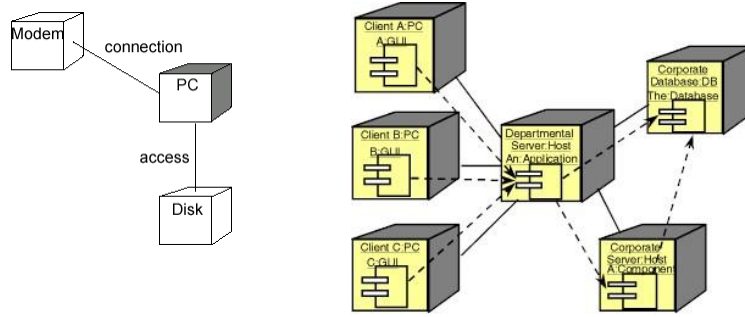

Deployment Example

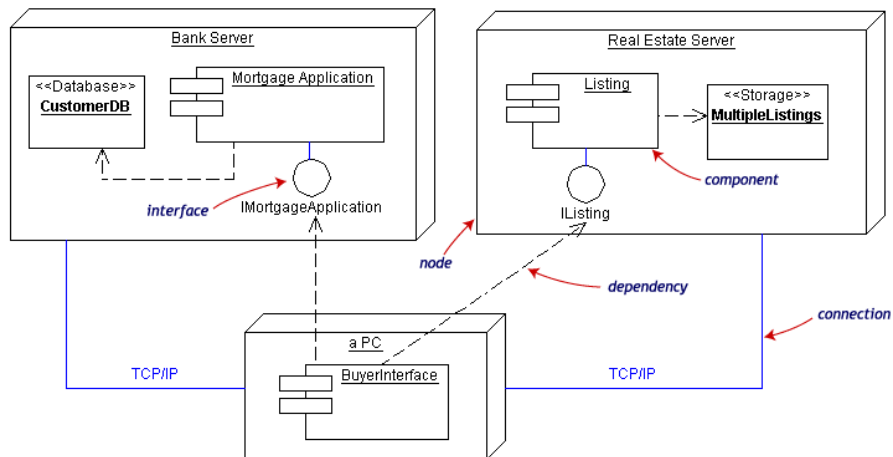

Often the Component Diagram is combined with the Deployment

Summary and Tools

- UML is a modeling language that can be used independent of development
- Adopted by OMG and notation of choice for visual modeling
 - <http://www.omg.org/uml/>
- Creating and modifying UML diagrams can be labor and time intensive.
- Lots of tools exist to help
 - Tools help keep diagrams, code in sync
 - Repository for a complete software development project
 - Examples here created with TogetherSoft ControlCenter, Microsoft Visio, Tablet UML
 - Other tools:
 - Rational, Cetus, Embarcadero
 - Google it to find free / commercial tools